



# RS

REEL SPLITTER

# Technical data and measurements

RS		100/200	150/250
Cutting force	kN	200	200
Power	kW	7,5	7,5
Reel diameter max.	mm	1.000	1.500
Reel width max.	mm	2.000	2.500
Cutting speed	cm/s	4,9	4,9
Knife return speed	cm/s	13,8	13,8
Reel splitter weight (according to equipment)	ca. t	4	9

Dimensions in mm	A	B	C	D	E	F	G
RS 100/200	1025	2050	4611	3649	2960	460	3605
RS 150/250	1575	2600	5793	5148	4270	825	3605

## Special FEATURES of the REEL SPLITTER:

- The electric/hydraulic operated splitting knife with diagonal cutting direction reduces the required forces and allows cutting of soft materials.
- The adjustable prismatic guide allows an accurate adjustment of the knife enabling cutting down to the bottom paper layers as well as reduction of the maintenance and wear costs.
- To increase the splitting capacity on small diameter reels a second knife position can be provided as an option. An interlocking system ensures the operational safety.
- The danger area around the splitting machine is secured by a safety light barrier for the rear splitting area and a knife cover in the upper end position. The operator is protected by using a two-hand control via push-button.

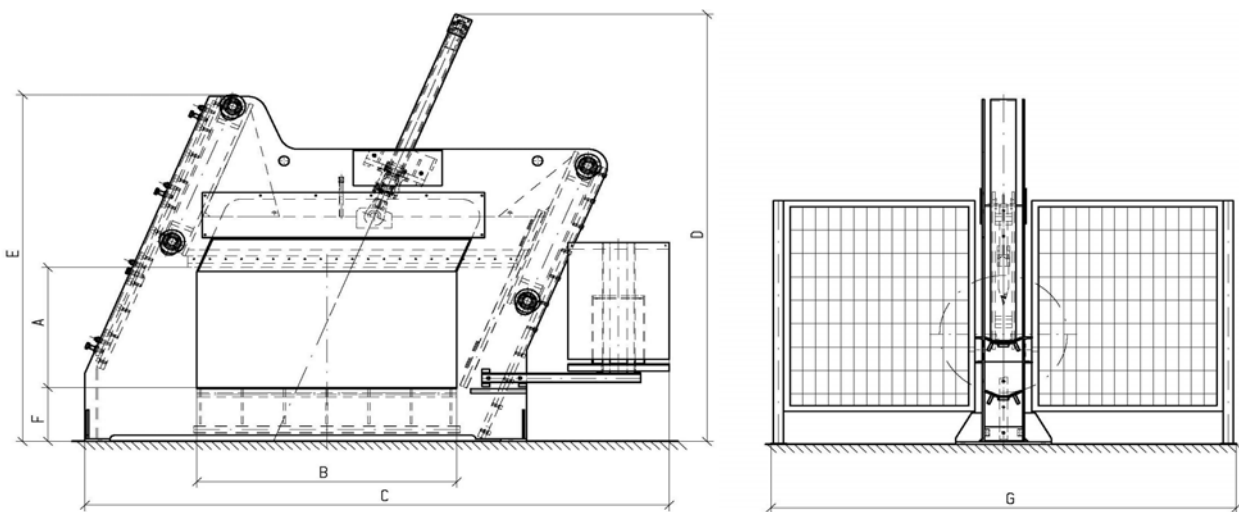

[www.paalgroup.com](http://www.paalgroup.com)

### PAAL®

PAAL GmbH  
Raiffeisenstraße 15-17  
49124 Georgsmarienhütte  
Germany

Tel.: +49 (0) 5401 488 0  
Fax.: +49 (0) 5401 488 13  
[info@paalgroup.com](mailto:info@paalgroup.com)

### FAES®

Amadeo Farell S.A.U.  
Poligono Industrial Can Carné  
Calle Montsià s/n, P.O. Box 125  
08211 Castellar del Vallés  
Spain

Tel.: +34 937 143 210  
Fax.: +34 937 143 169  
[info@faesnet.net](mailto:info@faesnet.net)

### DICOM

Dicom Ltd.  
Lydford Road  
Meadow Lane Industrial Estate  
Alfreton, Derbyshire DE55 7RQ  
Great Britain

Tel.: +44 (0) 177 352 0565  
Fax.: +44 (0) 177 352 0881  
[sales@dicom.ltd.uk](mailto:sales@dicom.ltd.uk)

### COMDEC

COMDECPAAL  
9, rue Gustave Eiffel  
21540 Sombornon  
France

Tel.: +33 (0) 3 80 33 49 26  
Fax.: +33 (0) 3 80 33 42 43  
[com@comdec-paal.com](mailto:com@comdec-paal.com)