

	CE12/20 T	CE15	CE32/30	CE32/30 T
Machine Capacity (m3)	9	12.12	25	25
Compaction Force (Tonnes)	20	26	30	30
Blade Penetration (mm)	150	115° Paddle	305	305
Cycle Time (Seconds)	40	32	48	48
Charge Box Volume (m3)	0.75	0.9	1.3	1.3
Volume Per Hour (m3)	67.5	101	97.5	97.5
Motor Size (kW)	4	5.5	5.5	5.5
Loading Height (mm)	1295	1143	1330	1330
Length (mm)	4835	4395	6412	7350
Width (mm)	1920	1870	2495	2495
Height (mm)	2230	2200	2745	2745
Door Opening (mm)	N/A	1105 x 762	N/A	N/A
Top Opening (mm)	1340 x 685	N/A	1700 x 1100	1700 x 1100

Features:

Lug Lift tipping system	•	N/A	N/A	•
Liquid Retentive Seal	Option	Option	•	•
Twin Hydraulic Rams	•	•	•	•
Programmable Logical Controller (PLC)	•	•	•	•
¾ Full Warning Light	•	•	•	•
Retaining teeth on header bar	•	N/A	•	•
Stress Engineered Body	•	•	•	•
24 Volt Controls	•	•	•	•
Emergency Stop Buttons	•	•	•	•
Dual Channel Safety Circuits	•	•	•	•
Automatic Shut down when full	•	•	•	•
External Grease Points	•	N/A	•	•
CE Certification	•	•	•	•
Bustle Gate Rear Door to increase compaction	•	•	•	•
Remote Power Pack (Std built in)	Option	Option	Option	Option
Low Loading Height	•	•	•	•
Custom Built Hopper	Option	Option	Option	Option

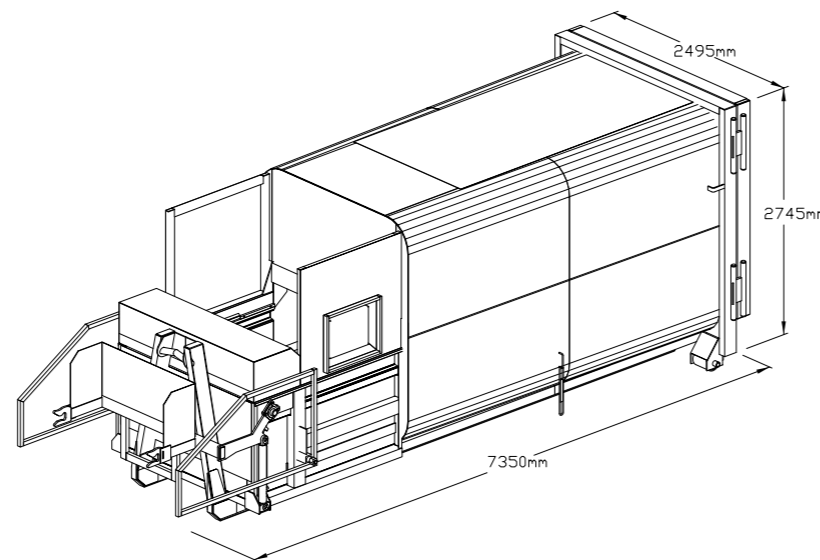
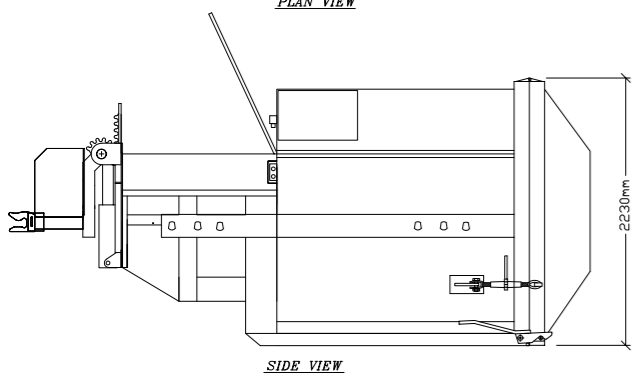
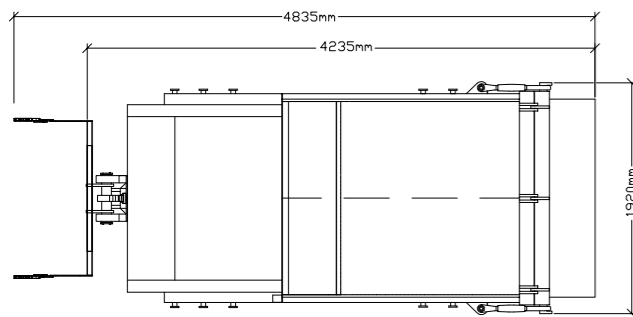

All dimensions are correct at time of print; however Dicom is continually improving our products and for space critical situations, dimensions can be confirmed.



CE

PORTABLE WASTE COMPACTORS

CE

PORTABLE WASTE COMPACTORS

The CE range is a well – established waste compactor from the Dicom PAAL Group and compliments the already existing wide range of waste handling equipment.

The CE range of portable waste compactors are powerful, reliable and efficient machines offering economic solutions for your daily waste handling requirements.

CE Compactors for economical operation

CE Range

The range of CE portable waste compactors are ideally suited for compacting materials such as dry industrial and commercial general waste, cardboard, plastic packaging, timber and recyclables.

Each has been designed to ensure you achieve maximum performance and reliability, with ease of operation.

Dicom Limited is the UK's leading manufacturer and supplier of waste compactors and baling equipment.

Safety

All Dicom's products are designed and manufactured with operator safety our highest priority.

Equipment is supplied with the following standard safety features:

- Emergency Stop
- 24 Volt control
- Dual safety switches
- Dual channel safety relays
- Operator manuals supplied

Each compactor comes fully compliant to all current Safety Standards and CE Marked.

During installation full safety and operator training is provided by our highly experienced installation and service engineers.

Designed for efficiency

Benefits

For those organisation producing larger volumes of waste, a considerable reduction in the number of collections can be achieved using a Dicom portable waste compactor. Waste can be reduced by a significant ratio of its original volume, depending on the material being compacted.

Maximum payloads are achieved with each container transported, dramatically reducing unnecessary journeys and easing traffic congestion and pollution.

Compacting your waste in a portable waste compactor will:

- Reduce the space needed to store waste on site
- Improve hygiene
- Increase security and reduce fire risk
- Improve Health & Safety

Dicom's portable waste compactors can be supplied with several standard options, such as:

- Liquid retentive seals to prevent food waste leakage
- Bin lifting equipment for lug and comb type waste containers
- Choice of standard hopper – open splayed, enclosed, dock loading

The Dicom CE range of portable waste compactors have been designed and developed over the last 25 years, for durability, high performance and ease of operations, with many machines still operating after 20 years.

Many customers are now using the CE portable waste compactors for recycling or general waste collection, where space and cleanliness are important factors. Typical locations are hospitals, schools and colleges, hotels, food production.



Why choose a portable waste compactor from Dicom?

- Dicom have been established in the UK for over 30 years.
- All compactors are designed, developed and built at our UK manufacturing site.
- All products are CE marked
- Great reliable and proven products
- The best after sales service in the industry, using our own engineers
- Purchase, Rental and finance options

How we can help you:

- FREE Site surveys and advice
- Product information and specification sheets
- Prompt proposals
- Very competitive pricing



We reserve the right to change dimensions and specifications. Colours may deviate topographically.